

## PERFORMANCES OF THE ELECTRIC VEHICLES WITH DIFFERENT CHARGING METHODS

Kristina Jakimovska<sup>1</sup>, Anita Vasileva<sup>1</sup>, Mikołaj Bartłomiejczyk<sup>2</sup>

<sup>1</sup>*Faculty of Mechanical Engineering, “Ss. Cyril and Methodius” University in Skopje,  
P.O. Box 464, MK-1001, Skopje, Republic of North Macedonia*

<sup>2</sup>*Gdańsk University of Technology, Faculty of Electric and Control Engineering,  
Department of Electrified Transportation, Gdańsk, Poland  
kristina.jakimovska@mf.edu.mk*

**Abstract:** Since the world pollution has been increased, the need for eco-solutions is alarming. One solution is electric vehicles, which have been rapidly developed in recent years. Those vehicles are energy efficient and emission free, but the initial costs can be much higher in comparison to other vehicles. This paper would focus on the methods of charging power and battery requirements as well as energy consumption. Analyzing the methods of charging for achieving environmentally friendly cities, as well as comparisons between the methods will greatly support the development of strategies for achieving zero emissions.

**Key words:** eco friendly; electric buses; electromobility

### ПЕРФОРМАНСИ НА ЕЛЕКТРИЧНИТЕ ВОЗИЛА СО РАЗЛИЧЕН МЕТОД НА ПОЛНЕЊЕ

**Апстракт:** Откако загадувањето е во постојан пораст, потребата од еко-решенија е алармантна. Едно решение се електричните возила чијашто употреба во последните години рапидно расте. Ваквите возила се енергетски ефикасни и без емисија на штетни гасови, но почетната инвестиција може да биде многу повисока во споредба со другите возила. Во овој труд се разгледуваат методите за напојување и батериите, како и потрошувачката на енергија. Анализирајќи ги методите за полнење заради постигнување еколошки градови, како и споредбите помеѓу нив, во голема мера треба да се поддржи развојот на стратегии за постигнување нулта емисија на штетни гасови.

**Клучни зборови:** екологија; електрични автобуси; електромобилност

### 1. INTRODUCTION

The charging of electric vehicles is a broad issue. Multiple classifications can be applied, depending on the choice of criteria [1, 2]. The most important criteria for classification are operational as well as technical aspects. Hence, we can distinguish [3, 4]:

- 1) division into charging strategies from the operational and motor aspect,
- 2) division into charging methods from a technical implementation point of view.

From the operating and operational point of view, there are four main charging strategies [5, 6]:

- 1) stationary charging overnight in the depot, low power 30 – 60 kW,
- 2) stationary charging in the depot together with recharging during the day using medium (100 – 200 kW) or high power (300 – 600 kW) charging stations,
- 3) fast charging only at end stations with high power (300 – 600 kW),
- 4) dynamic motion loading (In Motion Charging, IMC) [7].

From a technical point of view, charging methods can be divided as follows:

- charging with a plug-in connector,
- charging in a four-pole system,
- charging in a two-pole system,
- In motion charging (IMC) [8, 9].

In this paper charging strategies applied to electric buses will be further discussed. It should be noted that some charging strategies overlap with others in regard to technical criteria. Table 1

presents a comparison of technical charging methods in terms of the ability to handle individual charging strategies.

For example, vehicles adapted to the dynamic charging method may also work in a fast charging strategy or, in the case of having a sufficiently large battery, in night charging with recharging. A transport system using a fast charging strategy, can be operated by a four-wire, two-wire or dynamic four-wire method [10, 11].

Table 1

*Comparison of charging strategies and charging systems indicating which charging strategy can be implemented by means of which charging systems*

Charging strategy	Technical charging method			
	Plug-in	Four-pole system	Two-pole system	Dynamic charging
Night charging	yes	yes	yes	no
Night charging with re-charging during day	yes	yes	yes	yes
Fast charging	no	yes	yes	yes
Dynamic charging	no	no	no	yes

## 2. THE CHARGING STRUCTURES

### a) *Classification of charging strategies from the operational point of view*

The process of charging electric buses is a factor in determining the functioning of this means of transport in the public transport system. The charging time of traction batteries varies within a wide range, from several minutes up to several hours. The vehicle's working cycle is highly dependent on this charging time [12, 13]. Currently available battery technologies allow electric buses to achieve ranges between 150 and 200 km. Further increases in the coverage area require significant associated increases in battery weight [14, 15]. A range of 150 – 200 km is insufficient for servicing all-day tasks on public transport lines. It is therefore necessary to recharge the bus's battery within the working shift, which requires the vehicle to be removed from traffic. Therefore, in such an operational regime it is only possible to operate peak transportation routes [16].

The disadvantage of night charging is the very large capacity of the traction battery, which causes a significant increase in the weight of the vehicle. In addition, it also involves significant costs in replac-

ing the battery at the end of its lifetime. Reducing the capacity of the battery can be achieved by increasing the charging power to 300 – 600 kW as a result of which it is possible to significantly reduce its capacity up to 60 – 90 kWh leading to a reduction in the weight and dimensions of the battery [17, 18]. Charging the electric bus, however, requires the vehicle to be out of operation for a period of about 10–20 minutes. These periods must be incorporated in the timetable and require an increase in stopping times at the end terminuses or stops [19, 20]. As a result of this, more electric buses are required to operate the route compared to classic buses or trolley-buses. It is also possible to recharge traction batteries during stops along the route. This requires an extension of the stopping time to about one minute, which is possible only in special situations [21].

Another solution is the dynamic charging of vehicles (IMC). This involves the supply of electricity during movement and can be done in a wireless way (linear induction loops) or in a contact manner (traction network). Currently, the most widespread dynamic charging system is the trolleybus traction network. Work is also underway on the application of this type of power supply for trucks (eHighway project) and public transport vehicles (Electroroad) [22].

b) *Classification of charging methods from the technical point of view*

- Plug-in charging

Traction batteries, requiring charging, are installed in the buses to provide the power source. The easiest way to charge these batteries is to do so while the bus is at the depot for a stopover at night. This type of charging can be compared to refueling for internal combustion buses. Battery capacity is closely aligned with the range of the vehicle. Increasing the range requires increased battery capacity, which brings with it increased vehicle weight and energy consumption [23].

It is possible to charge via DC or AC current. Today, available solutions allow for charging with a current of 60 – 100 A, which corresponds to a charging power of up to 60 kW. Plug-in systems with higher power have been tested, even up to 500 kW, but they are not popular. Due to the limited power and troublesome process of manual connection of the vehicle to the power source, the use of this method is in practice limited to night charging mode. Figure 1 shows an example of a plug-in charging system [24].



Fig. 1. An example of a plug-in charging system (Bremen)

- Four-pole charging system

In a four-pole system, charging takes place using a DC voltage of 600 – 900 V. The vehicle is connected to the charging station by means of a pantograph collector with 4 connectors (wires – poles) [25]:

- positive charging pole,
- negative charging pole,
- protective grounding pole (so-called earthing),
- grounding control pole.

The protective grounding pole is used to provide protection against electric shock in the event of damage to the insulation of the electrical installation. Due to this safety requirement, it is necessary to ensure a reliable connection between the vehicle body and the earthing-grounding pole. This involves the need to control the earthing grounding connection and for this purpose, an additional grounding control pole is used. Additionally, a sensor wire may be used to transmit data between the vehicle and the charging station.

The charging station is equipped with a charging converter the so-called charger. Charging power is usually in the range of 150 – 350 kW, but installations with a capacity of up to 600 kW are used [26].

Figure 2 presents a schematic diagram of a four-pole charging system. The pantograph may be part of the vehicle (Figures 3 and 4).

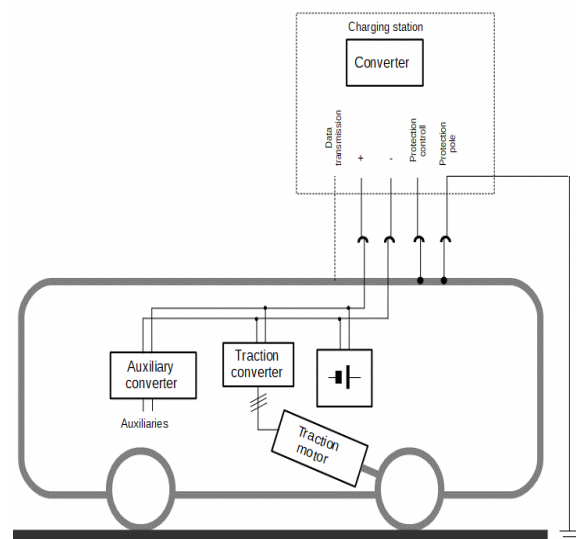

Fig. 2. Charging in four-pole system



Fig. 3. Pantograph of charging system Shunk (Kraków, Poland)

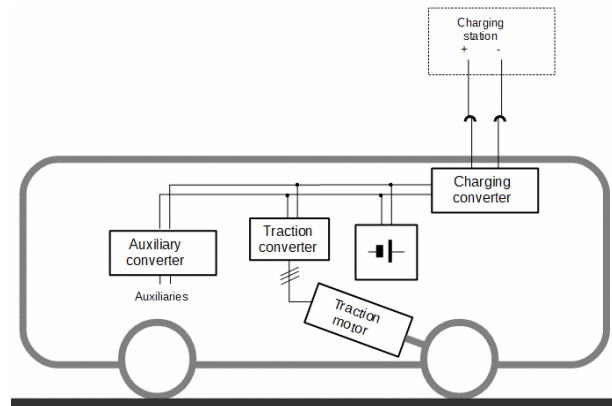

**Fig. 4.** Pantograph of charging system Opp Charge (Turku, Helsinki)

### c) Two-pole charging system

In a two-wire system, charging takes place using a DC voltage from 600 to 900 V. The vehicle is connected to the charging station by means of a pantograph collector containing 2 poles (positive and negative) from a short section of the trolleybus system. It is the simplest charging system for electric buses in the case of a previously existing tram or trolleybus overhead contact line. Charging may take place directly from an existing trolleybus infrastructure, whereas for a tram network it will be necessary to build a short section of the trolleybus network [27].

The basic problem for this charging system is providing protection against electric shock. Standard electric buses have electric installations made with single stage insulation. In a two-pole supply system, the vehicle body is not grounded. When charging an electric bus, there is a risk of electric shock if insulation is damaged. Therefore, it is not permissible to connect a non-earthed (non-grounded) electric vehicle equipped with a single stage electrical installation insulation to the electric power supply [28]. Consequently, for a charging method based on a two-pole system, it is necessary to incorporate two-stage insulation for the electrical installation of the vehicle (analogous to trolleybus insulation) or to use a separation converter in the vehicle, as shown schematically in Figure 5. The weight of this converter is between 200 and 600 kg, which significantly increases the weight of the vehicle. Implementation of the converter also involves financial outlays. It is possible to install a separation converter in a stationary form. This solution was used at the electric bus charging station in Prague (Figure 6) [29].



**Fig. 5.** Charging in two-pole system

The charging power in a two-pole system is limited by the maximum current of the pantograph collector. Currently used pantographs allow for a current of 200 – 300 A, which corresponds to 150 – 200 kW of charging power.



**Fig. 6.** Electric bus charged in two-pole system (Prague, Czech Republic)

### d) In motion charging (Dynamic charging)

The dynamic charging system is a combination of two-pole charging with trolleybus technology [30]. In the dynamic charging system, part of the route is covered with a trolleybus traction network, which allows for the charging of traction batteries during movement (Figure 7).

The vehicles cover the rest of the route, i.e. the part in which there is no contact line, using traction battery power [31]. This allows for the charging of the vehicle without stopping, increasing the flexibility and functionality of the system. In addition, covering a section of the route with a traction network reduces the length of the route to be travelled in battery mode, which in turn allows for a reduction in the capacity of the traction batteries.

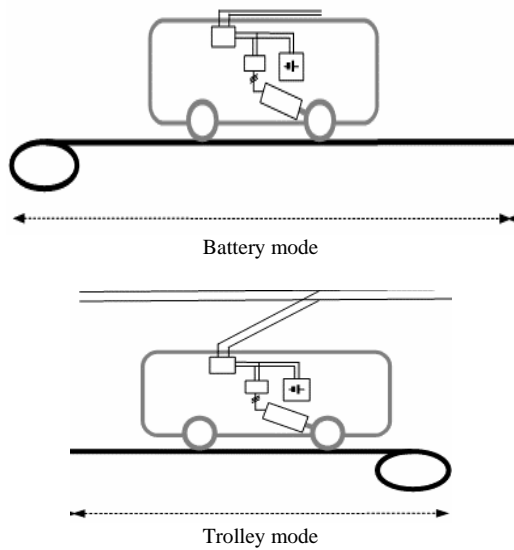

Fig. 7. Idea of dynamic charging system (In motion charging)

### 3. ANALYSIS AND DISCUSSION OF CHARGING METHODS

Every charging method has advantages and disadvantages. The main differences between Plug-in, Four-pole, Two-pole and IMC are presents on Table 2. The comparison is according the four criteria: Max. Charging power. Financial outlays flexibility, Advantages and Disadvantages [32].

According to the criteria, we have not that IMC has the best performances. The advantages of IMC is that it covers from 20 to 40% of the route by overhead wires, there is no need to stop for charging and also it is efficiency and flexibility [33]. The disadvantages of IMC include: high initial costs, high capital costs all of which prevent many investors from implementation.

Table 2

Comparison of charging methods

<b>PLUG- IN</b>	100 kW	Low	Middle	Low investment cost	Difficult manual connection
<b>FOUR- POLE</b>	600 kW	Middle	Low	The highest charging power	High cost of charging station
<b>TWO- POLE</b>	200 kW	Low	Low	Easily to integrate with tram or trolleybus supply	High cost of vehicle supply
<b>IMC</b>	300 kW while travelling, 80 kW while stopping	High	High	No need to stop vehicles during charging, more flexibility, less battery capacity	High investment cost

### 4. CONCLUSION

This research results show that the charging method has a central role in the implementation of electric vehicle, especially city buses [34]. As the initial cost of the charging stations are much high, the user to evaluate the electric buses performance, to optimize battery sizing and options for charging infrastructure, and identify opportunities and gaps associated with vehicle electrification in real world city bus transit service, needs to take into account the charging station use the different operating routs as well as many other analysis [35, 36].

Electric buses require a dedicated charging infrastructure. The BRT system in Marrakech (Morocco) (Figure 10) is an example of an urban transport system that uses dynamic charging through a traction network. The traction network is a reduced

one of a minimum size necessary to efficiently operate the route. Initially, the construction of a tram line was considered as in other Moroccan cities (Casablanca, Rabat).

However, due to the high costs, the electrified Bus Rapid Transit system was chosen instead. The BRT line was opened in September 2017 and connects the centre of the city with the western suburbs through Hassan II Avenue, with a total line length of 8 km. The length of the section covered by the catenary is 2.5 km [37]. The line is supplied with 750 V voltage from one traction substation located at the western end of the route. The BRT line operates on separated bus lanes along the entire length of the route (Figures 8 and 9). The line is serviced by 10 standard two-door Chinese YANGTSE trolleybuses. Each vehicle is equipment with 5 battery packs. Each battery pack has a capacitance

of 200 Ah nominal voltages 115.2 V. The total energy capacitance of the batteries is 115.2 kWh. The trolleybus overhead line will be supplied from a 1 MW/h photovoltaic plant with an area of 3 ha. The energy generated from the photovoltaic panels will be transferred to the 750 V DC power systems with any unused surplus being sold to the power system operator [38]. The interval of service on the line is 6 min in peak time. In the future there are plans to buy higher capacitance vehicles and extend the route to Medina, the historical centre of Marrakesh [39]. The BRT system in Marrakesh can

be seen as an example of a modern electrified transportation system that could potentially be a much cheaper alternative to tram transport with identical transportation capacity [40].

Other EU cities where is implement a different variation of electric buses, are illustrated in Table 3 [41, 42].

The article has been prepared within project Efficiency Energy Efficiency for Public Transport Infrastructure in Central Europe funded by the Interreg Central Europe under grant agreement CE1537.



**Fig. 8.** The western end of the catenary section of Marrakesh's BRT system



**Fig. 9.** The eastern end of the catenary section of Marrakesh's BRT system

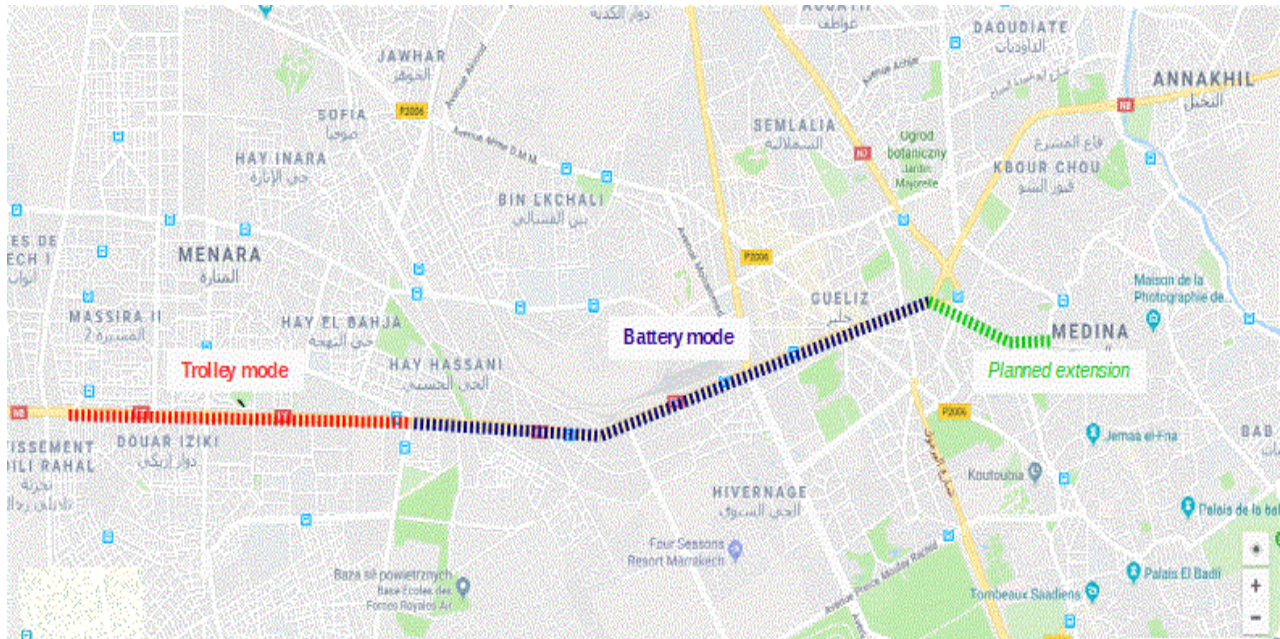

Fig. 10. The scheme of Marrakesh's BRT system

Table 3  
Bus rapid transit in EU cities

City, Country	Characteristics	
	Length (km)	Average speed (km/h)
Paris, France	41.20	23.5
Leeds, UK	1.5	20
Dublin, Ireland	100.0	18
Stockholm, Sweden	24.1	15
Essen, Germany	24	16.5
Eindhoven, the Netherlands	15	21.0
Helsinki, Finland	27.50	26.0
Zurich, Switzerland	11	19
Istanbul, Turkey	52	35.0
Cambridge, UK	40	60

## REFERENCES

- [1] Bartłomiejczyk, M.: *Dynamic Charging of Electric Buses*, De Gruyter, Warsaw, Poland, 2018.
- [2] Bartłomiejczyk, M.: Practical application of a motion charging: Trolleybuses service on bus lines, *Proceedings of the 18<sup>th</sup> International Scientific Conference on Electric Power Engineering (EPE)*, 17–19 May 2017, pp. 1–6. (DOI: 10.1109/EPE.2017.7967239).
- [3] Bartłomiejczyk, M.: Smart grid technologies in electric power supply systems of public transport, *Proceedings of the 12<sup>th</sup> International Conference: Modern Electrified Transport*, pp. 8–14, 2015.
- [4] Bartłomiejczyk, M., Połom, M.: Possibilities for developing electromobility by using autonomously powered trolleybuses based on the example of Gdynia. *Energies*, Vol. 14, No. 2971, pp. 2–23 (2021).
- [5] Barraza, O., Estrada, M.: Battery electric bus network: Efficient design and cost comparison of different powertrains, *Sustainability*, Vol. 13, No. 9, 4745 (2021).
- [6] Krawiec, S., Krawiec, K.: Rozwój elektromobilności w Polsce. Uwarunkowania, cele i bariery., *Zesz. Nauk. Uniw. Ekon. w Katowicach*, Vol. 332, pp. 17–21 (2017).
- [7] Jefferies, D., Göhlich, D.: A Comprehensive TCO evaluation method for electric bus systems based on discrete-event simulation including bus scheduling and charging infrastructure optimisation, *World Electric Vehicle Journal*, Vol. 11, No. 56, pp. 2–43 (2020).
- [8] Ke, B. R., Chung, C. Y., Chen, Y. C.: Minimizing the costs of constructing an all plug-in electric bus transportation system, A case study in Penghu. *Appl. Energy*, No. 177, pp. 649–660 (2016).
- [9] Wołek, M., Wolański, M., Bartłomiejczyk, M., Wyszomirski, O., Grzelec, K., Hebel, K.: Ensuring sustainable development of urban public transport: A case study of the trolleybus system in Gdynia and Sopot (Poland), *Journal of Cleaner Production*, Vol. 279, No. 123807, (2021).
- [10] Vilppo, O., Markkula, J.: Feasibility of electric buses in public transport, In: *Proceedings of the EVS28 International Electric Vehicle Symposium and Exhibition*, Seoul, Korea, 3–5 May 2015, Vol. 7, pp. 1–9.
- [11] Bartłomiejczyk, M., Połom, M.: Sustainable use of the catenary by trolleybuses with auxiliary power sources on the example of Gdynia, *Infrastructures*, Vol. 6, No. 6, pp. 1–17 (2021).
- [12] Tomaszewski, K.: The Polish road to the new European Green Deal – challenges and threats to the national energy policy, *Energy Policy Journal*, No. 23, pp. 5–18 (2020).
- [13] Depré, C., Guida, U.: *An Updated Overview of Electric Buses in Europe*, ZeEUS eBus Report Brussels, Belgium, No. 2 (2018).

- [14] Brdulak, A., Chaberek, G., Jagodziński, J.: Development forecasts for the zero-emission bus fleet in servicing public transport in chosen EU member countries, *Energies*, Vol. **13**, No. 4239, pp. 1–19 (2020).
- [15] An, K.: Battery electric bus infrastructure planning under demand uncertainty, *Transp. Res. Part C Emerg. Technol.*, No. 111, pp. 572–587 (2020).
- [16] Paul, T., Yamada, H.: Operation and charging scheduling of electric buses in a city bus route network, In: *Proceedings of the 17<sup>th</sup> International IEEE Conference on Intelligent Transportation Systems (ITSC)*, Qingdao, China, 8–11 October 2014, pp. 2780–2786.
- [17] May, N.: Local environmental impact assessment as decision support for the introduction of electromobility in urban public transport systems, *Transp. Res. Part D Transp. Environ.*, No. 64, pp. 192–203 (2018).
- [18] Gokce, K.: Performance evaluation of a newly designed robotized gearbox for electric city buses, *Mechanika*, No. 23, pp. 639–645 (2017).
- [19] Wierzbowski, M., Filipiak, I., Łyzwa, W.: Polish energy policy 2050 – An instrument to develop a diversified and sustainable electricity generation mix in coal-based energy system, *Renew. Sustain. Energy Rev.*, No. 74, pp. 51–70 (2017).
- [20] Kühne, R.: Electric buses – An energy efficient urban transportation means, *Energy*, No. 35, pp. 4510–4513 (2010).
- [21] Rocco, M. V., Casalegno, A., Colombo, E.: Modeling road transport technologies in future scenarios: Theoretical comparison and application of Well-to-Wheels and Input-Output analyses, *Appl. Energy*, No. 232, pp. 583–597 (2018).
- [22] Maglaras, L. A., Jiang, J., Maglaras, A., Topalis, F. V., Moschoyiannis, S.: Dynamic wireless charging of electric vehicles on the move with Mobile Energy Disseminators, *International Journal of Advanced Computer Science and Applications*, Vol. **6**, No. 6 (2015).
- [23] Vaez-Zadeh, S., Babaki, A., Zakerian, A.: *Connected and Autonomous Vehicles in Smart Cities*, *Dynamic Wireless Charging of Electric Vehicles*, CRC Press, pp. 407–435, 2020.
- [24] Binetti, G., Davoudi, A., Naso, D., Turchiano, B., Lewis, F.L.: Scalable real-time electric vehicles charging with discrete charging rates, *IEEE Trans. Smart Grid*, No. 6, pp. 2211–2220 (2015).
- [25] Boglou, V., Karavas, C.-S., Arvanitis, K., Karlis, A.: A fuzzy energy management strategy for the coordination of electric vehicle charging in low voltage distribution grids, *Energies*, Vol. **13**, No. 3709 (2020).
- [26] Mohamed, N., Aymen, F., Mouna, B. H.: Wireless charging system for a mobile hybrid electric vehicle, In: *Proceedings of the International Symposium on Advanced Electrical and Communication Technologies (ISAECT)*, 2018.
- [27] Mahmoud, M., Garnett, R., Ferguson, M., Kanaroglou, P.: Electric buses: A review of alternative powertrains, *Renewable & Sustainable Energy Review*, No. 62, pp. 673–684 (2016).
- [28] Muratori, M.: Impact of uncoordinated plug-in electric vehicle charging on residential power demand, *Nat. Energy*, No. 3, pp. 193–201 (2018).
- [29] Rogge, M., Van der Hurk, E., Larsen, A., Sauer, D. U.: Electric bus fleet size and mix problem with optimization of charging infrastructure, *Appl. Energy*, No. 211, pp. 282–295 (2018).
- [30] An, K.: Battery electric bus infrastructure planning under demand uncertainty, *Transp. Res. Part C. Emerg. Technol.* Vol. **111**, pp. 572–587 (2020).
- [31] Zhang, A., Li, T., Zheng, Y., Li, X., Abdullah, M.G., Dong, C.: Mixed electric bus fleet scheduling problem with partial mixed-route and partial recharging, *International Journal of Sustainable Transportation*, pp. 1–11 (2021).
- [32] Deliali, A., Chhan, D., Oliver, J., Sayess, R., Godri Pollitt, K. J., Christofa, E.: Transitioning to zero-emission bus fleets: state of practice of implementations in the United States, *Transport Reviews*, Vol. **41**, No. 2, pp. 164–191 (2021).
- [33] Sun, Z., Wang, C., Ye, Z., Bi, X.: Long short-term memory network-based emission models for conventional and new energy buses, *International Journal of Sustainable Transportation*, Vol. **15**, No. 3, pp. 229–238, 2021.
- [34] Zhou, Y., Cathy Liu, X., Wei, R., Golub, A.: Bi-objective optimization for battery electric bus deployment considering cost and environmental equity, *IEEE Transactions on Intelligent Transportation Systems*, Vol. **22**, No. 4, pp. 2487–2497 (2021).
- [35] Alwesabi, Y., Liu, Z., Kwon, S., Wang, Y.: A novel integration of scheduling and dynamic wireless charging planning models of battery electric buses, *Energy*, Vol. **230**, No. 1 (2021).
- [36] Zhang, W., Zhao, H., Song, Z.: Integrating transit route network design and fast charging station planning for battery electric buses, *IEEE Access*, Vol. **9**, pp. 51604–51617 (2021).
- [37] Zhang, X., Nie, S., He, M., Wang, J.: *Case Studies in Thermal Engineering*, Charging system analysis, energy consumption, and carbon dioxide emissions of battery electric buses in Beijing, Elsevier, Vol. **26**, 2021.
- [38] Hoekstra, A.: The underestimated potential of battery electric vehicles to reduce emissions, *Joule*, Vol. **3**, No. 6, pp. 1412–1414 (2019).
- [39] Teixeira, A. C. R., Sodré, J. R.: Impacts of replacement of engine powered vehicles by electric vehicles on energy consumption and CO<sub>2</sub> emission, *Transport. Res. D*, Vol. **59**, pp. 375–384 (2018).
- [40] Gao, Z. M., Lin, Z. H., LaClair, T., Liu, C. Z., Li, J. M., Birky, A. K.: Battery capacity and recharging needs for electric buses in city transit service, *Energy*, Vol. **122**, No. 1, pp. 588–600 (2017).
- [41] Canales, C., Estrada, M., Thorson, L., Robuste F.: *Public Transport Policies in Europe: Implementing bus rapid transit systems in major European cities*, Association for European Transport and Contributors, June 2006.
- [42] EMBARQ, BRT+: [www.brtdata.org](http://www.brtdata.org), [https://brtdata.org/indicators/systems/operating\\_speed](https://brtdata.org/indicators/systems/operating_speed) (2021).